

CD4071B, CD4072B, CD4075B Types

CMOS OR Gates

High-Voltage Types (20-Volt Rating)

CD4071B Quad 2-Input OR Gate

CD4072B Dual 4-Input OR Gate

CD4075B Triple 3-Input OR Gate

The RCA-CD4071B, CD4072B, and CD4075B OR gates provide the system designer with direct implementation of the positive-logic OR function and supplement the existing family of CMOS gates. The CD4071, CD4072, and CD4075 types are supplied in 14-lead dual-in-line ceramic packages (D and F suffixes), 14-lead dual-in-line plastic packages (E suffix), 14-lead ceramic flat packages (K suffix), and in chip form (H suffix).

Features:

- Medium-Speed Operation- t_{PLH} , $t_{PHL} = 60$ ns (typ.) at $V_{DD} = 10$ V
- 100% tested for quiescent current at 20 V
- Maximum input current of $1 \mu A$ at 18 V over full package-temperature range; 100 nA at 18 V and 25°C
- Standardized, symmetrical output characteristics
- Noise margin (over full package temperature range)
 - 1 V at $V_{DD} = 5$ V
 - 2 V at $V_{DD} = 10$ V
 - 2.5 V at $V_{DD} = 15$ V
- 5-V, 10-V, and 15-V parametric ratings
- Meets all requirements of JEDEC Tentative Standard No. 13 A, "Standard Specifications for Description of 'B' Series CMOS Devices"

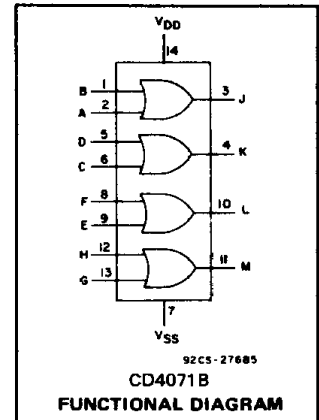

RECOMMENDED OPERATING CONDITIONS

For maximum reliability, nominal operating conditions should be selected so that operation is always within the following ranges:

| CHARACTERISTIC | LIMITS | | UNITS |
|---|--------|------|-------|
| | MIN. | MAX. | |
| Supply-Voltage Range (For T_A = Full Package-Temperature Range) | 3 | 18 | V |

STATIC ELECTRICAL CHARACTERISTICS

| CHARACTERISTIC | CONDITIONS | | | LIMITS AT INDICATED TEMPERATURES (°C) | | | | | | | UNITS |
|---|------------|--------------|--------------|---|-----------|---------|---------|--|---------------|-----------|---------|
| | | | | Values at -55, +25, +125 Apply to D, F, K, H Packages | | | | Values at -40, +25, +85 Apply to E Package | | | |
| | V_O (V) | V_{IN} (V) | V_{DD} (V) | -55 | -40 | +85 | +125 | Min. | Typ. | Max. | |
| Quiescent Device Current, I_{DD} Max. | - | 0,5 | 5 | 0.25 | 0.25 | 7.5 | 7.5 | - | 0.01 | 0.25 | μA |
| | - | 0,10 | 10 | 0.5 | 0.5 | 15 | 15 | - | 0.01 | 0.5 | |
| | - | 0,15 | 15 | 1 | 1 | 30 | 30 | - | 0.01 | 1 | |
| | - | 0,20 | 20 | 5 | 5 | 150 | 150 | - | 0.02 | 5 | |
| Output Low (Sink) Current I_{OL} Min. | 0.4 | 0,5 | 5 | 0.64 | 0.61 | 0.42 | 0.36 | 0.51 | 1 | - | mA |
| | 0.5 | 0,10 | 10 | 1.6 | 1.5 | 1.1 | 0.9 | 1.3 | 2.6 | - | |
| | 1.5 | 0,15 | 15 | 4.2 | 4 | 2.8 | 2.4 | 3.4 | 6.8 | - | |
| Output High (Source) Current, I_{OH} Min. | 4.6 | 0,5 | 5 | -0.64 | -0.61 | -0.42 | -0.36 | -0.51 | -1 | - | mA |
| | 2.5 | 0,5 | 5 | -2 | -1.8 | -1.3 | -1.15 | -1.6 | -3.2 | - | |
| | 9.5 | 0,10 | 10 | -1.6 | -1.5 | -1.1 | -0.9 | -1.3 | -2.6 | - | |
| | 13.5 | 0,15 | 15 | -4.2 | -4 | -2.8 | -2.4 | -3.4 | -6.8 | - | |
| Output Voltage: Low-Level, V_{OL} Max. | - | 0,5 | 5 | 0.05 | | | | - | 0 | 0.05 | V |
| | - | 0,10 | 10 | 0.05 | | | | - | 0 | 0.05 | |
| | - | 0,15 | 15 | 0.05 | | | | - | 0 | 0.05 | |
| Output Voltage: High-Level, V_{OH} Min. | - | 0,5 | 5 | 4.95 | | | | 4.95 | 5 | - | V |
| | - | 0,10 | 10 | 9.95 | | | | 9.95 | 10 | - | |
| | - | 0,15 | 15 | 14.95 | | | | 14.95 | 15 | - | |
| Input Low Voltage, V_{IL} Max. | 0.5, 4.5 | - | 5 | 1.5 | | | | - | - | 1.5 | V |
| | 1, 9 | - | 10 | 3 | | | | - | - | 3 | |
| | 1.5, 13.5 | - | 15 | 4 | | | | - | - | 4 | |
| Input High Voltage, V_{IH} Min. | 4.5 | - | 5 | 3.5 | | | | 3.5 | - | - | V |
| | 9 | - | 10 | 7 | | | | 7 | - | - | |
| Input Current I_{IN} Max. | - | 0,18 | 18 | ± 0.1 | ± 0.1 | ± 1 | ± 1 | - | $\pm 10^{-5}$ | ± 0.1 | μA |
| | - | - | - | - | - | - | - | - | - | - | |

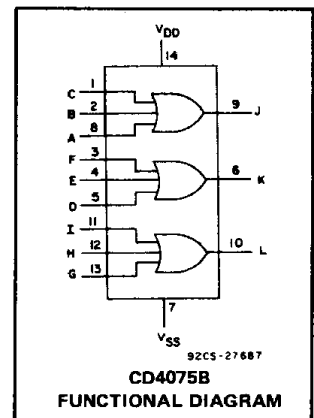
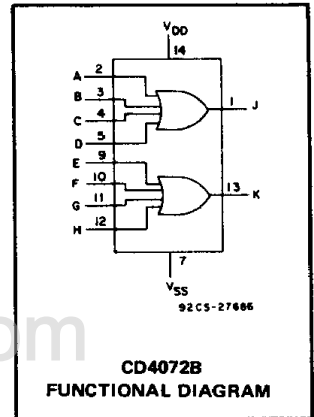

CD4071B, CD4072B, CD4075B Types

MAXIMUM RATINGS, Absolute-Maximum Values:

| | |
|--|---------------------------------------|
| DC SUPPLY-VOLTAGE RANGE, (V _{DD}) (Voltages referenced to V _{SS} Terminal) | -0.5 to +20 V |
| INPUT VOLTAGE RANGE, ALL INPUTS | -0.5 to V _{DD} +0.5 V |
| DC INPUT CURRENT, ANY ONE INPUT | ±10 mA |
| POWER DISSIPATION PER PACKAGE (P _D): | |
| For T _A = -40 to +80°C (PACKAGE TYPE E) | 500 mW |
| For T _A = +80 to +85°C (PACKAGE TYPE E) | Derate Linearly at 12 mW/°C to 200 mW |
| For T _A = -55 to +100°C (PACKAGE TYPES D, F, K) | 500 mW |
| For T _A = +100 to +125°C (PACKAGE TYPES D, F, K) | Derate Linearly at 12 mW/°C to 200 mW |
| DEVICE DISSIPATION PER OUTPUT TRANSISTOR: | |
| For T _A = FULL PACKAGE-TEMPERATURE RANGE (All Package Types) | 100 mW |
| OPERATING-TEMPERATURE RANGE (T _A): | |
| PACKAGE TYPES D, F, K, H | -55 to +125°C |
| PACKAGE TYPE E | -40 to +85°C |
| STORAGE TEMPERATURE RANGE (T _{stg}) | -65 to +150°C |
| LEAD TEMPERATURE (DURING SOLDERING): | |
| At distance 1/16 ± 1/32 inch (1.59 ± 0.79 mm) from case for 10 s max. | +265°C |

DYNAMIC ELECTRICAL CHARACTERISTICS at T_A = 25°C, Input t_r, t_f = 20 ns, and C_L = 50 pF, R_L = 200 kΩ

| CHARACTERISTIC | TEST CONDITIONS | ALL TYPES LIMITS | | UNITS | |
|---|-----------------|-----------------------|------|-------|------|
| | | V _{DD} VOLTS | TYP. | | MAX. |
| Propagation Delay Time, t _{PHL} , t _{PLH} | | 5 | 125 | 250 | ns |
| | | 10 | 60 | 120 | |
| | | 15 | 45 | 90 | |
| Transition Time, t _{THL} , t _{TLH} | | 5 | 100 | 200 | ns |
| | | 10 | 50 | 100 | |
| | | 15 | 40 | 80 | |
| Input Capacitance, C _{I(N)} | Any Input | — | 5 | 7.5 | pF |

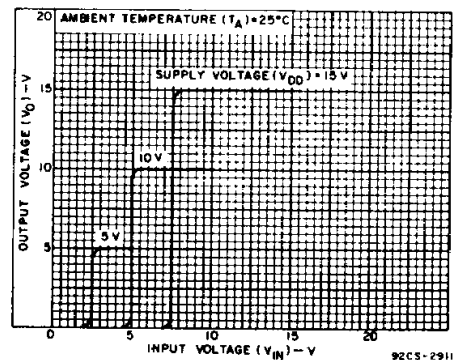
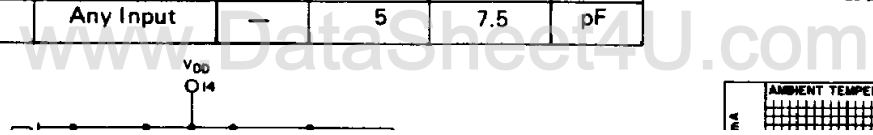

Fig. 1 – Typical voltage transfer characteristics.

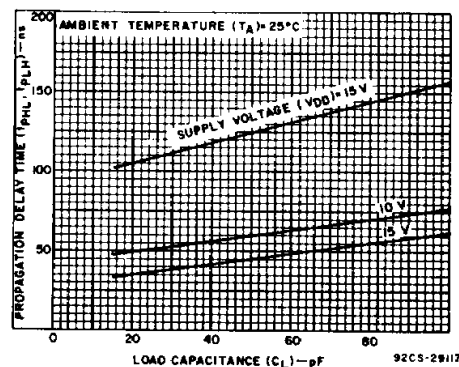

Fig. 2 – Typical propagation delay time as a function of load capacitance.



CD4071B, CD4072B, CD4075B Types

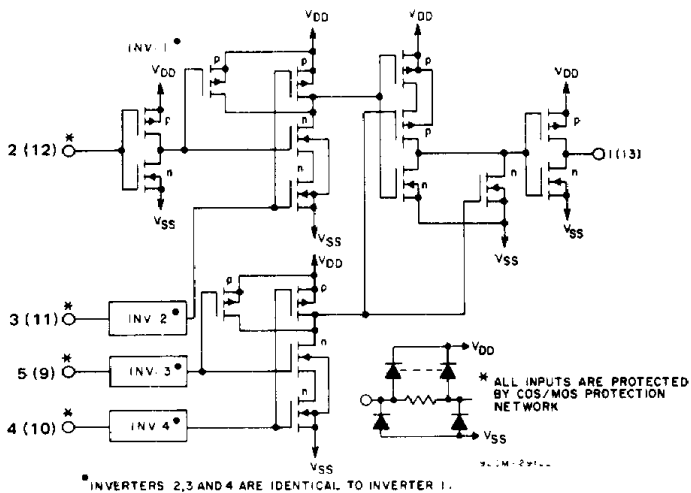

Fig. 7 - Schematic diagram for CD4072B (1 of 2 identical gates).

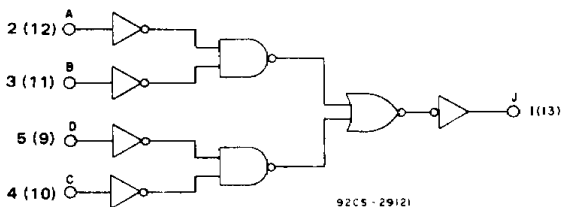

Fig. 9 - Logic diagram for CD4072B (1 of 2 identical gates).

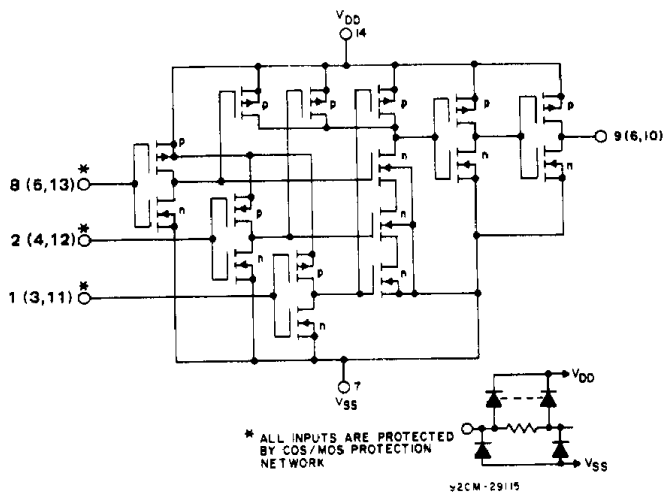

Fig. 11 - Schematic diagram for CD4075B (1 of 3 identical gates).

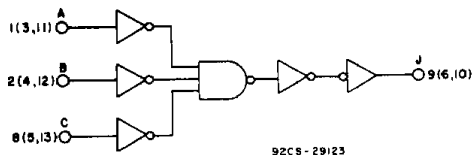

Fig. 13 - Logic diagram for CD4075B (1 of 3 identical gates).

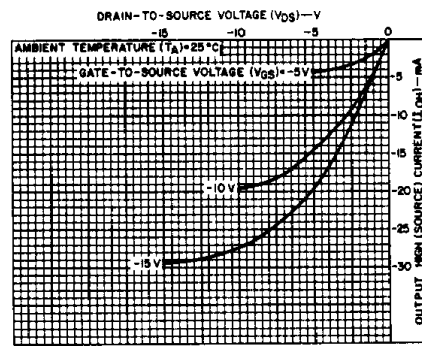

Fig. 8 - Typical output high (source) current characteristics.

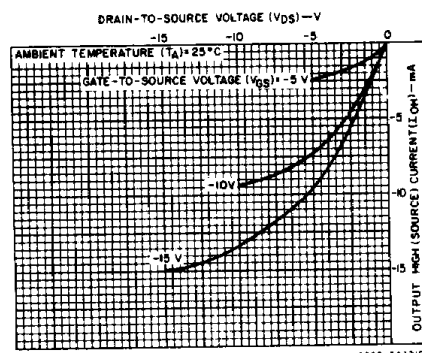

Fig. 10 - Minimum output high (source) current characteristics.

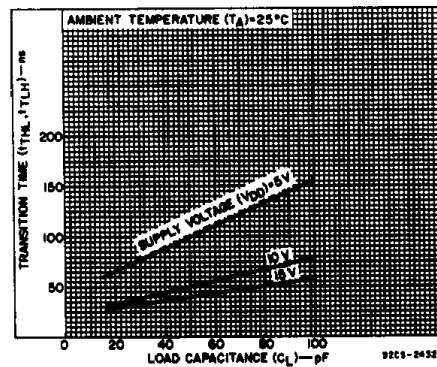

Fig. 12 - Typical transition time as a function of load capacitance.

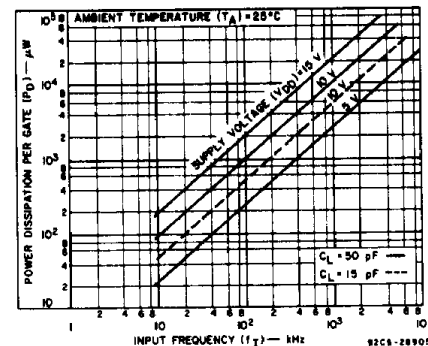

Fig. 14 - Typical dynamic power dissipation as a function of frequency.

CD4071B, CD4072B, CD4075B Types

TERMINAL ASSIGNMENTS (TOP VIEW)

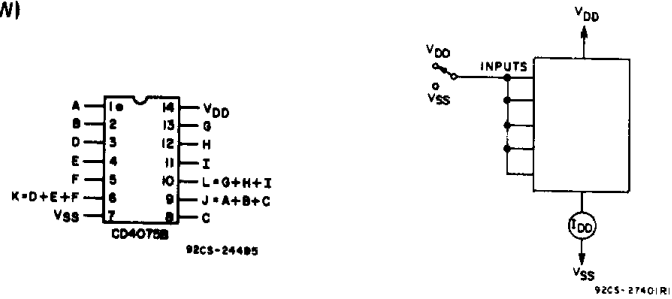
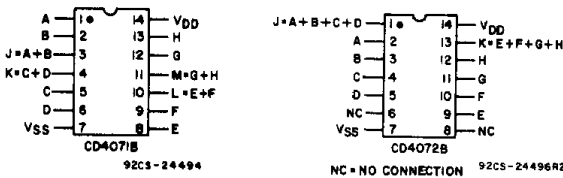

Fig. 15 - Quiescent device current test circuit.

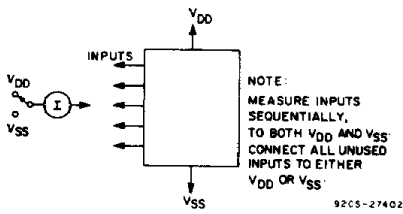

Fig. 16 - Input current test circuit.

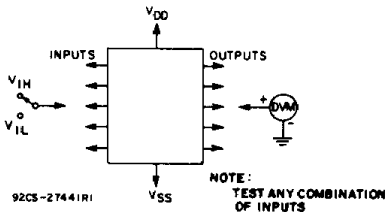
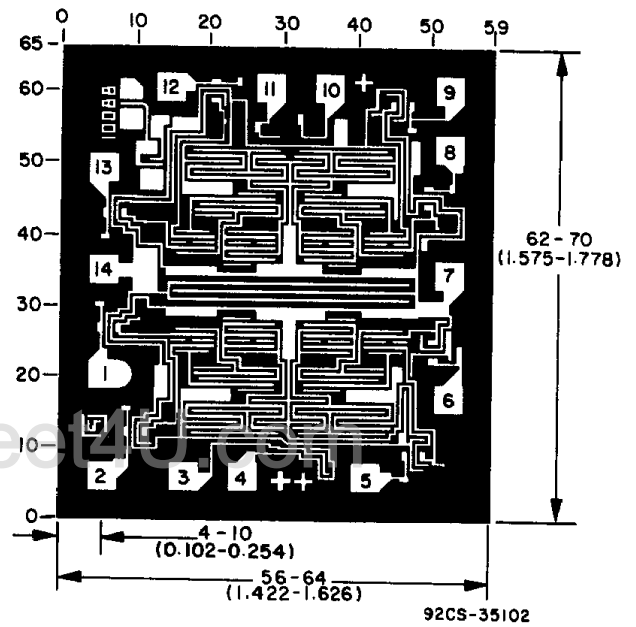

Fig. 17 - Input-voltage test circuit.

Dimensions in parentheses are in millimeters and are derived from the basic inch dimensions as indicated. Grid graduations are in mils (10^{-3} inch).

The photographs and dimensions of each CMOS chip represent a chip when it is part of the wafer. When the wafer is separated into individual chips, the angle of cleavage may vary with respect to the chip face for different chips. The actual dimensions of the isolated chip, therefore, may differ slightly from the nominal dimensions shown. The user should consider a tolerance of -3 mils to $+16$ mils applicable to the nominal dimensions shown.



Dimensions and pad layout for CD4071B.

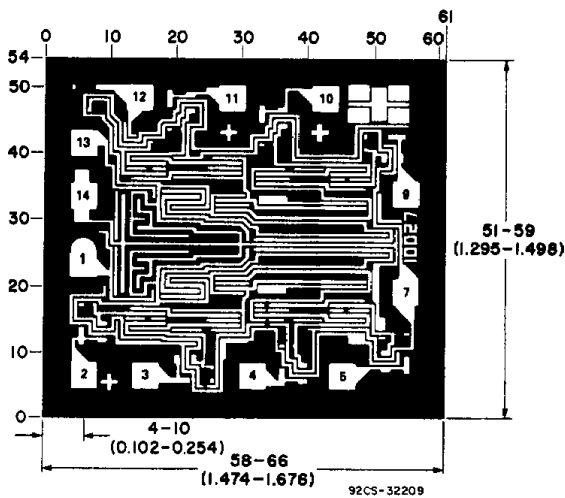

Dimensions and pad layout for CD4072B.

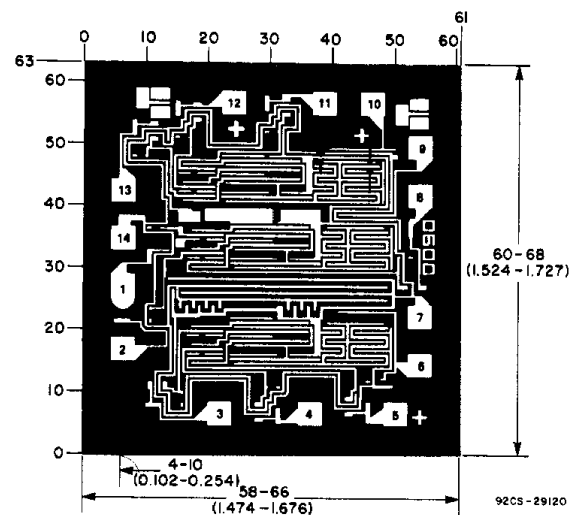

Dimensions and pad layout for CD4075B.